

**DIPLOMA EXAMINATION IN ENGINEERING/TECHNOLOGY/MANAGEMENT/  
COMMERCIAL PRACTICE – NOVEMBER – 2022**

**MACHINE DRAWING**

(Maximum Marks : 100)

(Time : 3 hours)

- [Note:-1. All dimensions are in mm  
2. First angle projections is to be followed.  
3. Missing data if any may be suitably assumed.  
4. Both sides of the drawing sheet may be used.  
5. Sketches accompanied.]

**UNIT -I**

Marks

**I.** Draw the profile of the following thread forms with its standard proportions

- (a) Whitworth Standard Thread.  
(b) Acme Thread.  
(c) Metric Thread.

(15)

**OR**

**II.** (a) Give the proportions and empirical relations of a single riveted single strap Butt-Joint. (9)

(b) Draw the following rivet heads with their proportions.

- (i) Snap head.      (ii) Pan head.      (iii) Flat head.      (6)

**UNIT – II**

**III.** A disassembled view of a Knuckle joint is shown in figure 1. Draw the sectional elevation and top view of the same. (30)

**OR**

**IV.** A disassembled view of an un-protected type flange coupling is shown in figure 2. Draw the half – sectional front view. (30)

**UNIT – III**

**V.** A sectional Isometric view of bushed bearing is shown in figure 3.

Draw (a) The sectioned elevation with dimensions.

- (b) An un-sectioned top view. (40)

**OR**

- VI.** The components shown in the figures are used to form a footstep bearing that is pad, bush and Block. Shown in figures 4.1, 4.2 and 4.3 and draw half-sectional front view of foot-step bearing. (40)

**UNIT – IV**

- VII.** Draw the illustration and symbols of the following welded joints.

- (i) Single – V butt weld
- (ii) Single – U butt weld (parallel or sloping sides)
- (iii) Fillet weld.
- (iv) Spot weld.
- (v) Seam weld. (15)

**OR**

- VIII.** Double line orthographic layout of a piping system shown in figure 5. Draw the single line layout. (15)

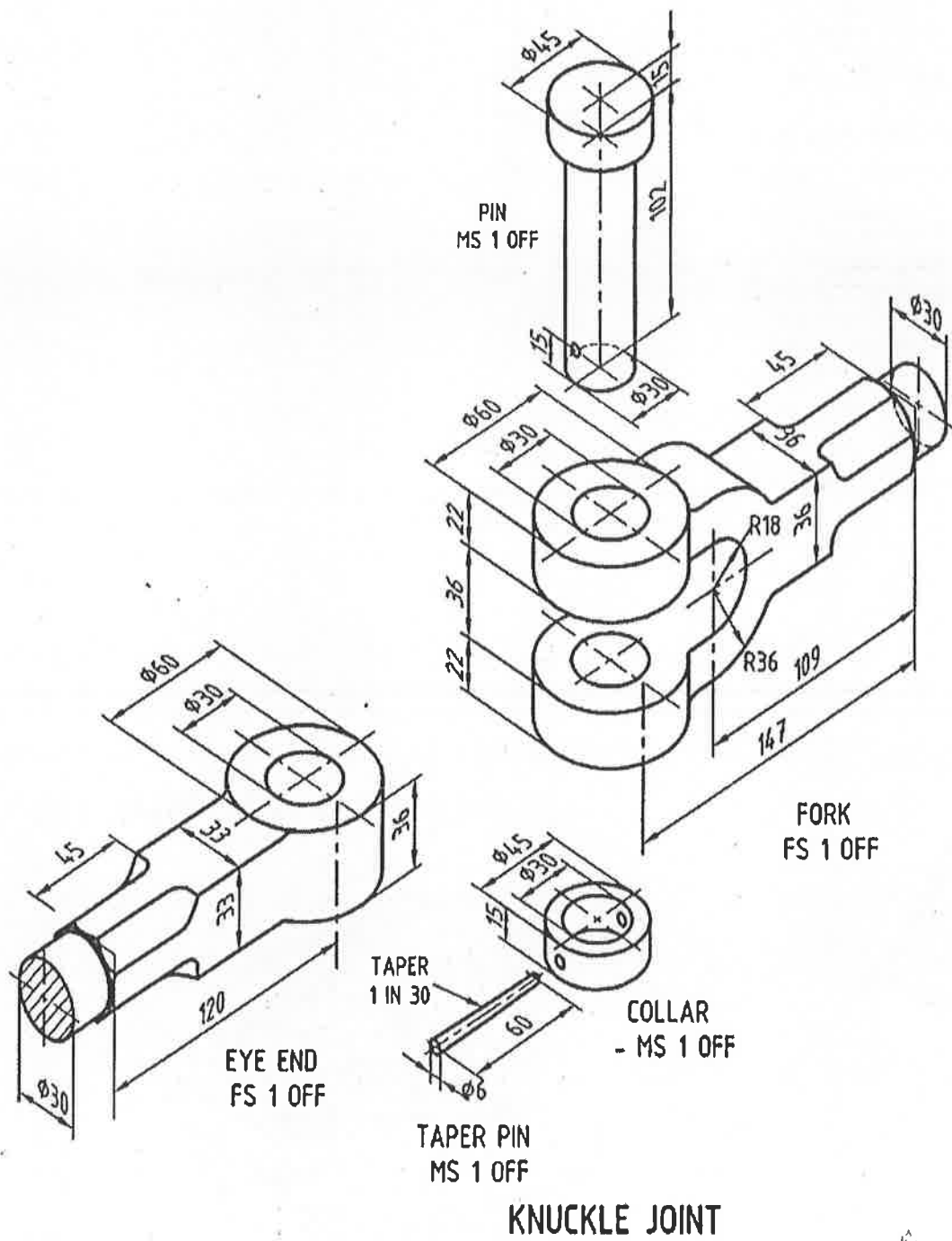

**FIGURE-1**



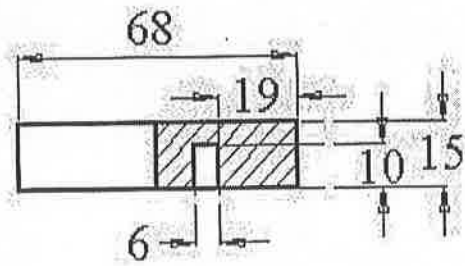

FIGURE 4.1 PAD

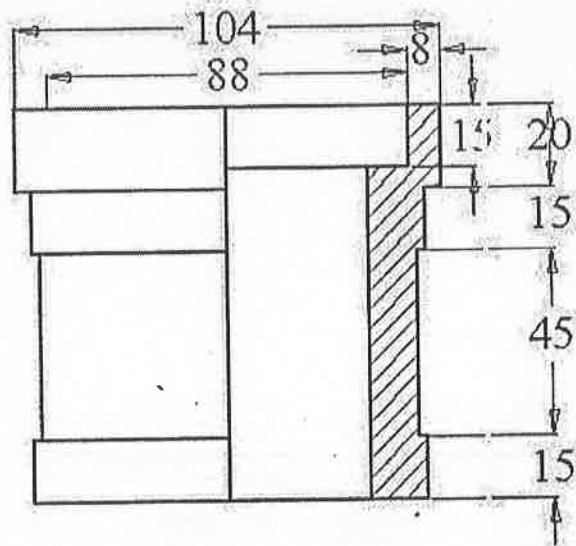

FIGURE 4.2 BUSH

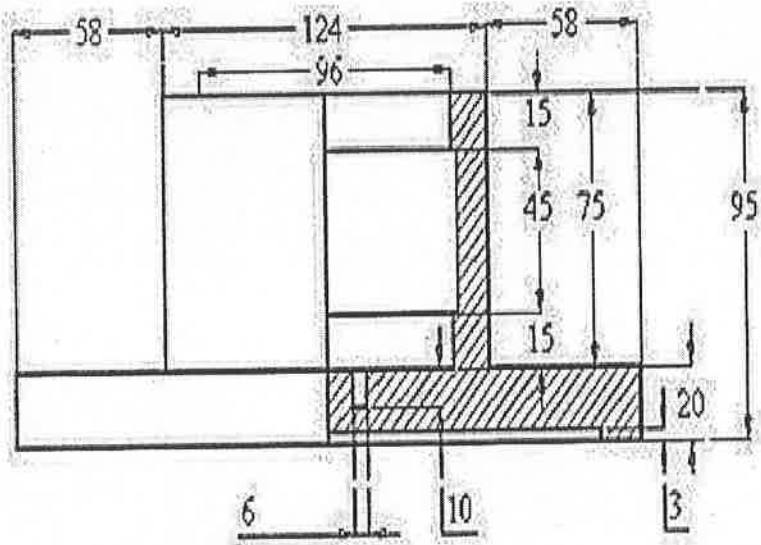
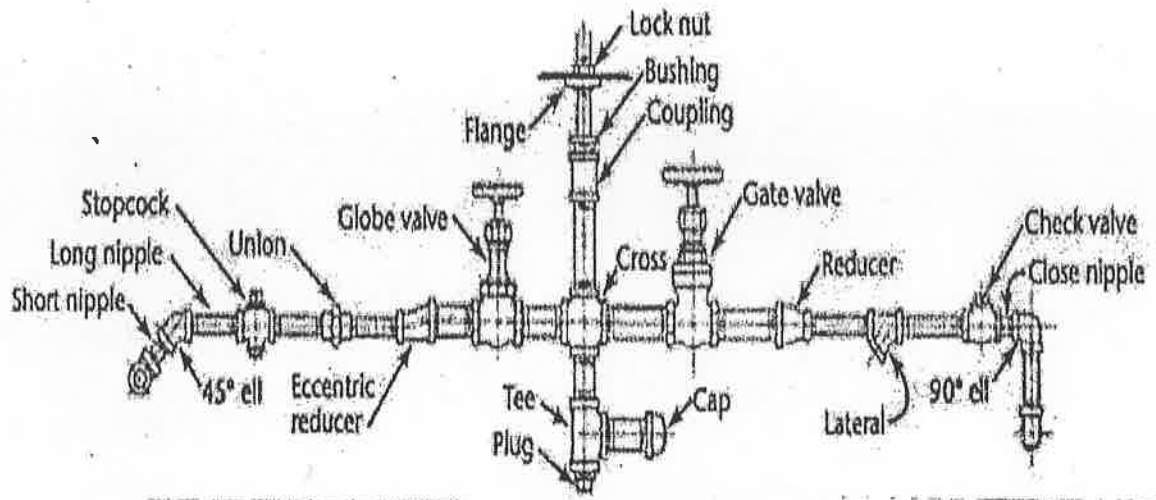

FIGURE 4.3 BLOCK



**FIGURE-5**

\*\*\*\*\*